

Unit with cyclo speed reducer (Cyclo pack)

<CHHCM02-6095>

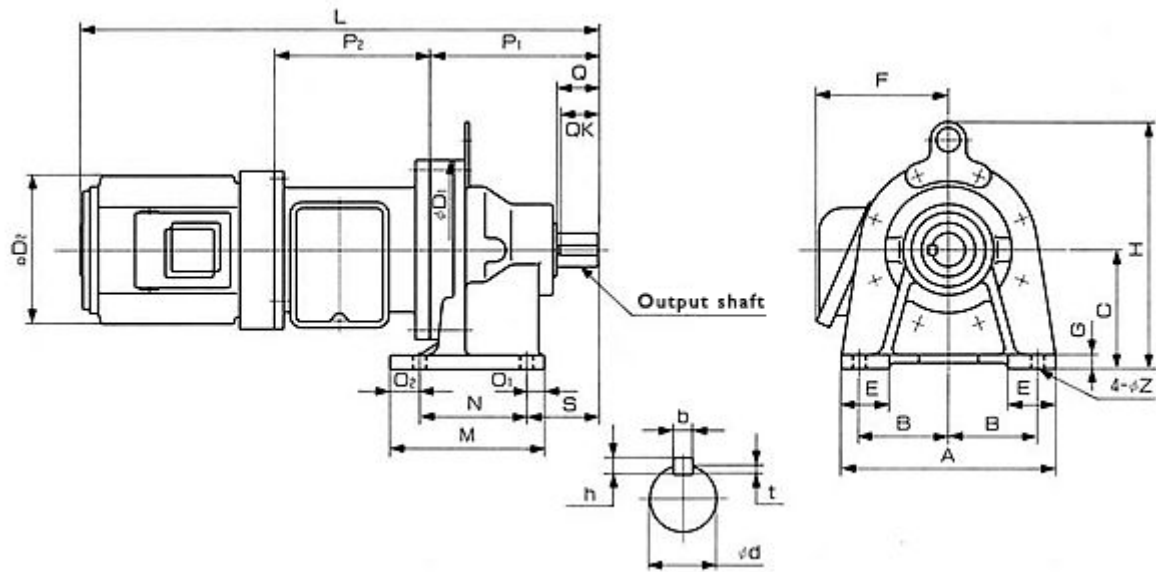

Unit:mm

Type		CHHCM02-6095	Shaft direction		Shaft edge	
Diameter direction	A	180	L	436	Q	35
	B	75	M	130	QK	32
	C	100	N	90	d	28
	D ₁	150	O ₁	15	b	8
	D ₂	124	O ₂	25	h	7
	E	40	P ₁	142	t	4
	F	111	P ₂	131		
	G	12	S	60		
	H	207	Z	11		

Unit with cyclo speed reducer (Cyclo pack)

<CHHCM02-6105>

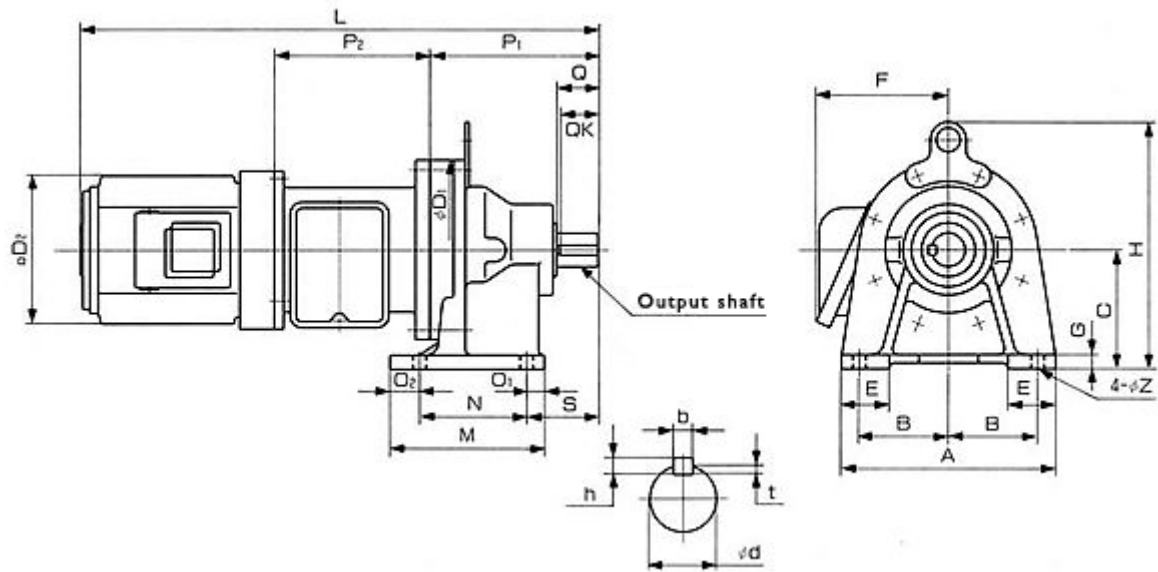

Unit:mm

Type		CHHCM02-6095	Shaft direction		Shaft edge	
Diameter direction	A	180	L	450	Q	35
	B	75	M	135	QK	32
	C	100	N	90	d	28
	D ₁	150	O ₁	15	b	8
	D ₂	124	O ₂	30	h	7
	E	40	P ₁	156	t	4
	F	111	P ₂	131		
	G	12	S	60		
	H	207	Z	11		

Unit with cyclo speed reducer (Cyclo pack)

<CHHCM05-6095>

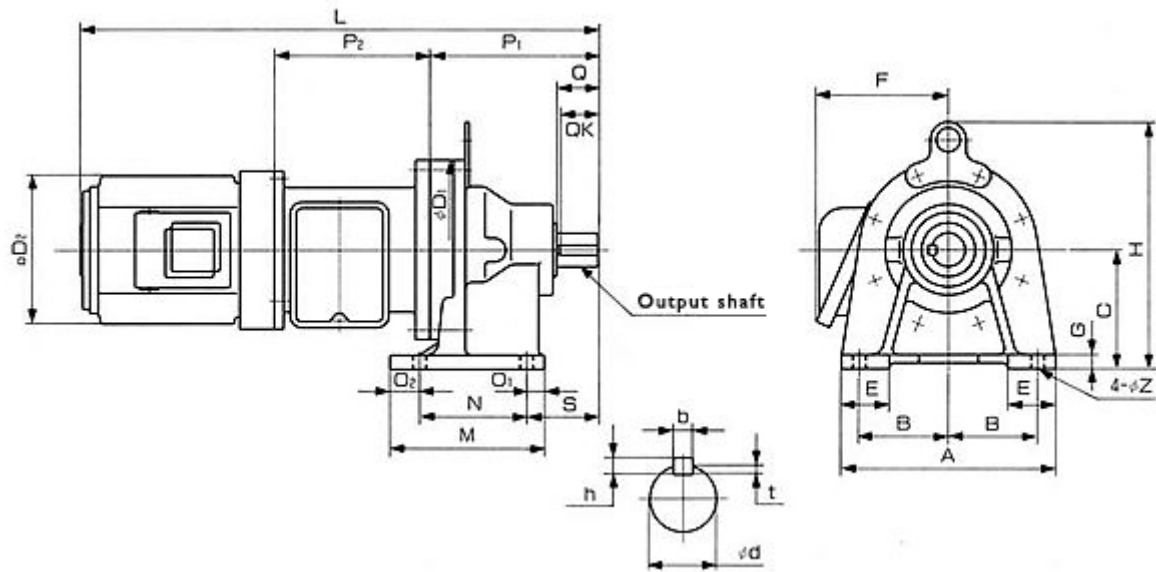

Unit:mm

Type		CHHCM05-6095	Shaft direction		Shaft edge	
Diameter direction	A	180	L	465	Q	35
	B	75	M	130	QK	32
	C	100	N	190	d	28
	D ₁	150	O ₁	15	b	8
	D ₂	132	O ₂	25	h	7
	E	40	P ₁	142	t	4
	F	111	P ₂	131		
	G	12	S	60		
	H	207	Z	11		

Unit with cyclo speed reducer (Cyclo pack)

<CHHCM05-6105>

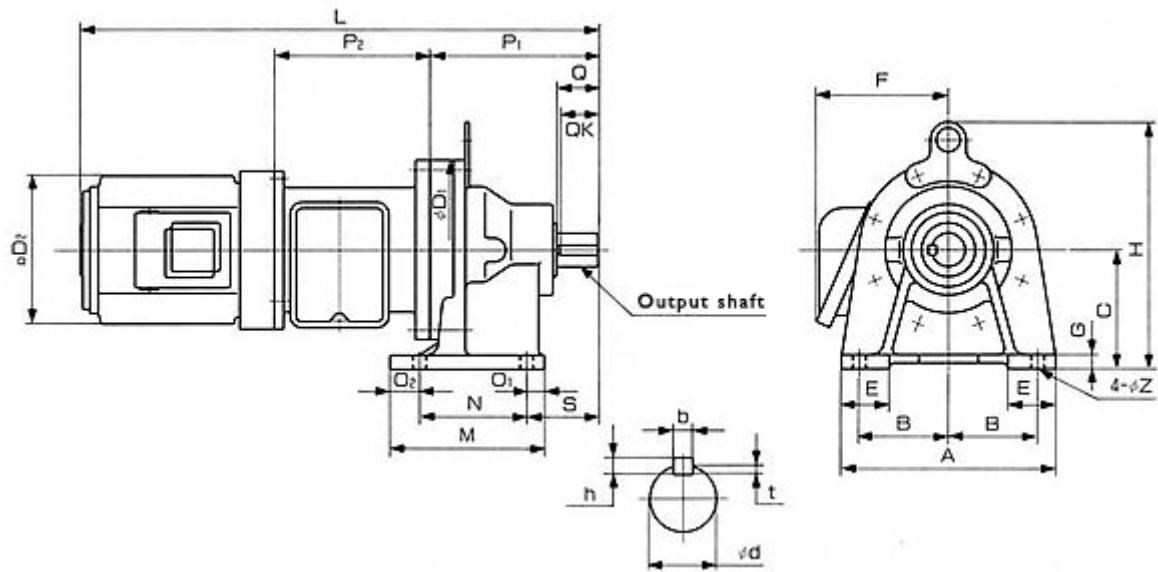

Unit:mm

Type	CHHCM05-6105	Shaft direction		Shaft edge	
Diameter direction	A	L	479	Q	35
	B	M	135	QK	32
	C	N	90	d	28
	D ₁	O ₁	15	b	8
	D ₂	O ₂	30	h	7
	E	P ₁	156	t	4
	F	P ₂	131		
	G	S	60		
	H	Z	11		

Unit with cyclo speed reducer (Cyclo pack)

<CHHCM05-6115>

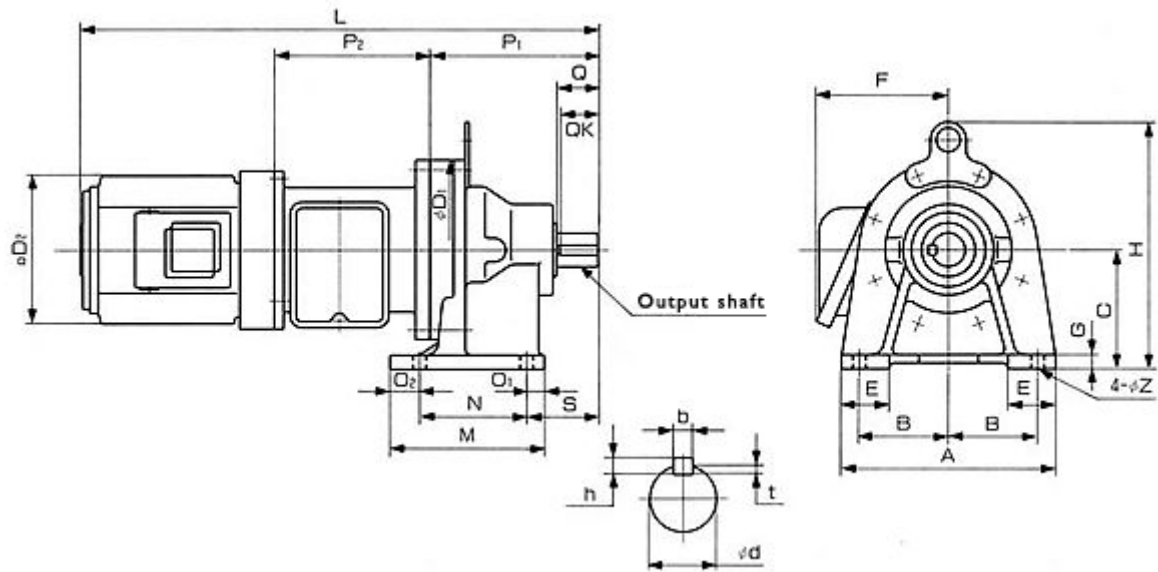

Unit:mm

Type		CHHCM05-6115	Shaft direction		Shaft edge	
Diameter direction	A	230	L	509	Q	55
	B	95	M	155	QK	50
	C	120	N	115	d	38
	D ₁	204	O ₁	20	b	10
	D ₂	132	O ₂	20	h	8
	E	55	P ₁	186	t	5
	F	111	P ₂	131		
	G	15	S	82		
	H	257	Z	14		

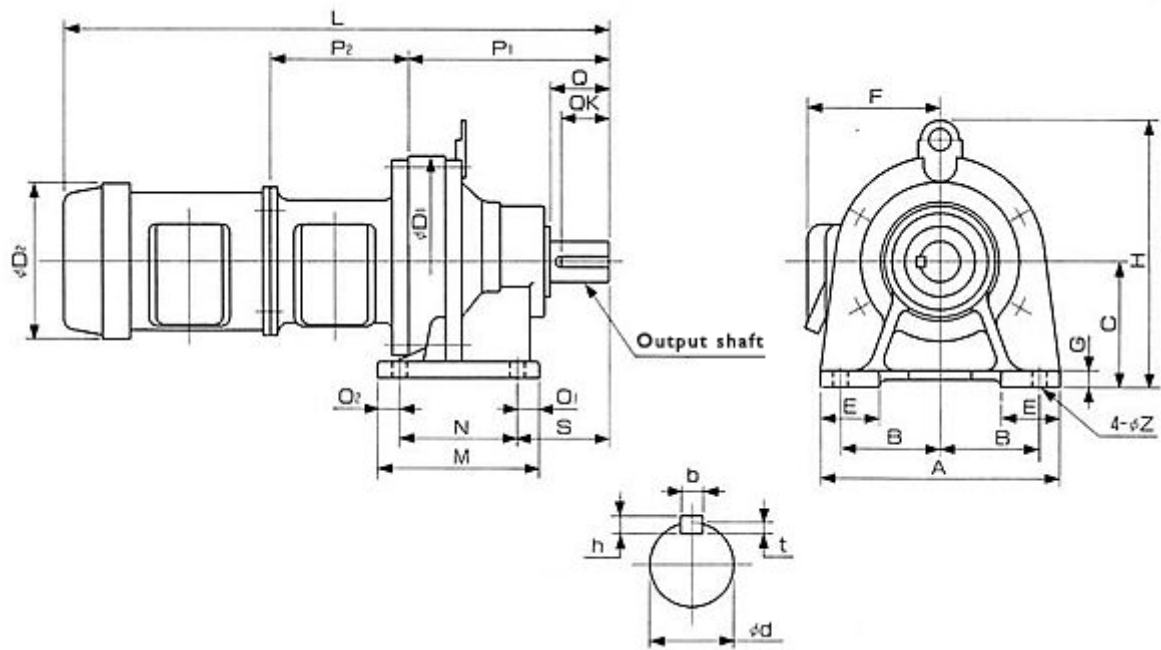
Unit with cyclo speed reducer (Cyclo pack)
<CHHCM1-6105-EP>

Unit:mm

Type		CHHCM1-6105-EP	Shaft direction		Shaft edge	
Diameter direction	A	180	L	552	Q	35
	B	75	M	135	QK	32
	C	100	N	90	d	28
	D ₁	150	O ₁	15	b	8
	D ₂	162	O ₂	30	h	7
	E	40	P ₁	156	t	4
	F	127	P ₂	141		
	G	12	S	60		
	H	214	Z	11		

Unit with cyclo speed reducer (Cyclo pack)

<CHHCM1-6125-EP>

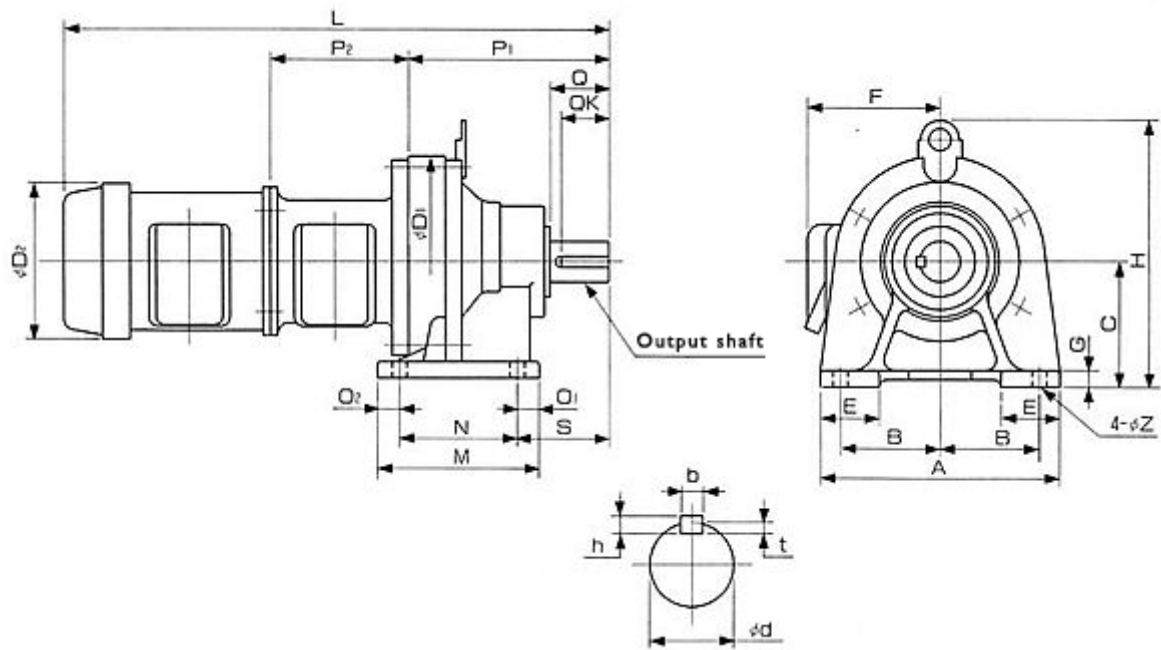

Unit:mm

Type		CHHCM1-6125-EP	Shaft direction		Shaft edge	
Diameter direction	A	230	L	582	Q	55
	B	95	M	155	QK	50
	C	120	N	115	d	38
	D ₁	204	O ₁	20	b	10
	D ₂	162	O ₂	20	h	8
	E	60	P ₁	186	t	5
	F	127	P ₂	141		
	G	15	S	82		
	H	234	Z	14		

Unit with cyclo speed reducer (Cyclo pack)

<CHHCM2-6105-EP>

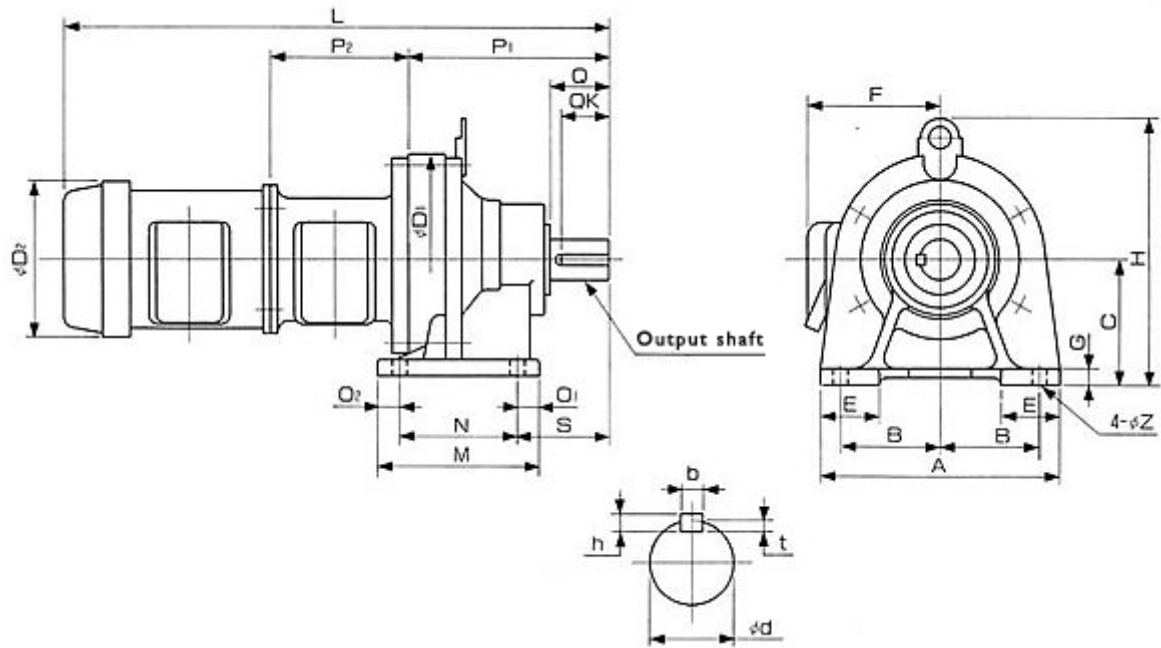

Unit:mm

Type		CHHCM2-6105-EP	Shaft direction		Shaft edge	
Diameter direction	A	180	L	579.5	Q	35
	B	75	M	135	QK	32
	C	100	N	90	d	28
	D ₁	150	O ₁	15	b	8
	D ₂	202	O ₂	30	h	7
	E	40	P ₁	156	t	4
	F	148	P ₂	161		
	G	12	S	60		
	H	239	Z	11		

Unit with cyclo speed reducer (Cyclo pack)

<CHHCM2-6125-EP>

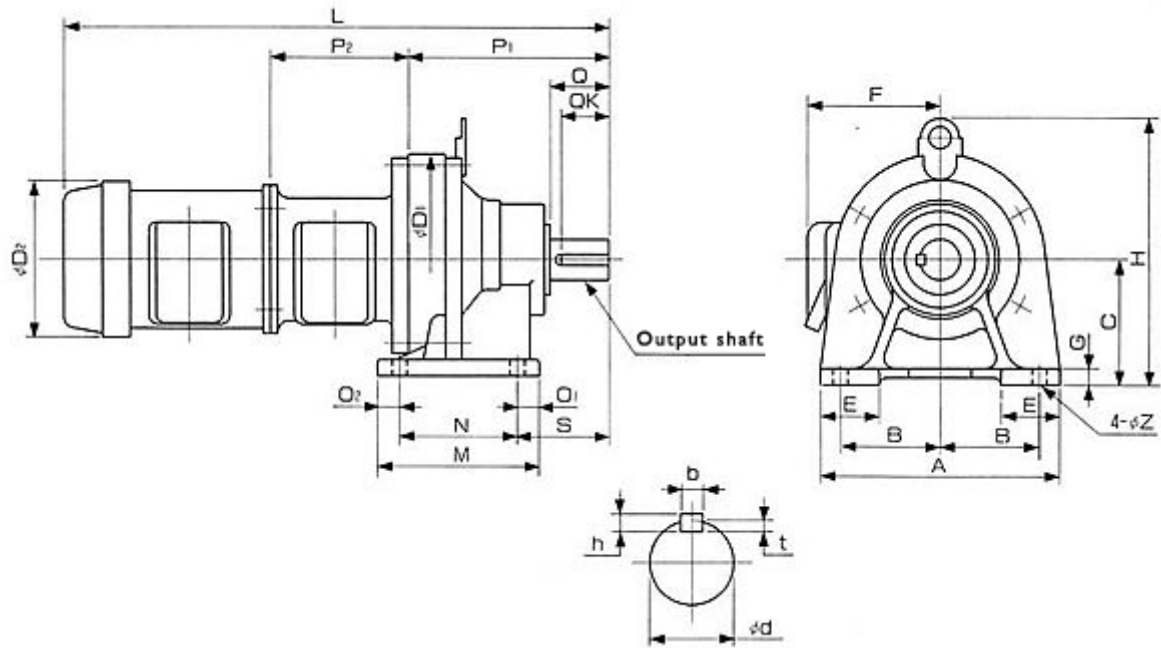

Unit:mm

Type		CHHCM2-6125-EP	Shaft direction		Shaft edge	
Diameter direction	A	230	L	609.5	Q	55
	B	95	M	155	QK	50
	C	120	N	115	d	38
	D ₁	204	O ₁	20	b	10
	D ₂	202	O ₂	20	h	8
	E	55	P ₁	186	t	5
	F	148	P ₂	161		
	G	15	S	82		
	H	259	Z	14		

Unit with cyclo speed reducer (Cyclo pack)

<CHHCM3-6125-EP>

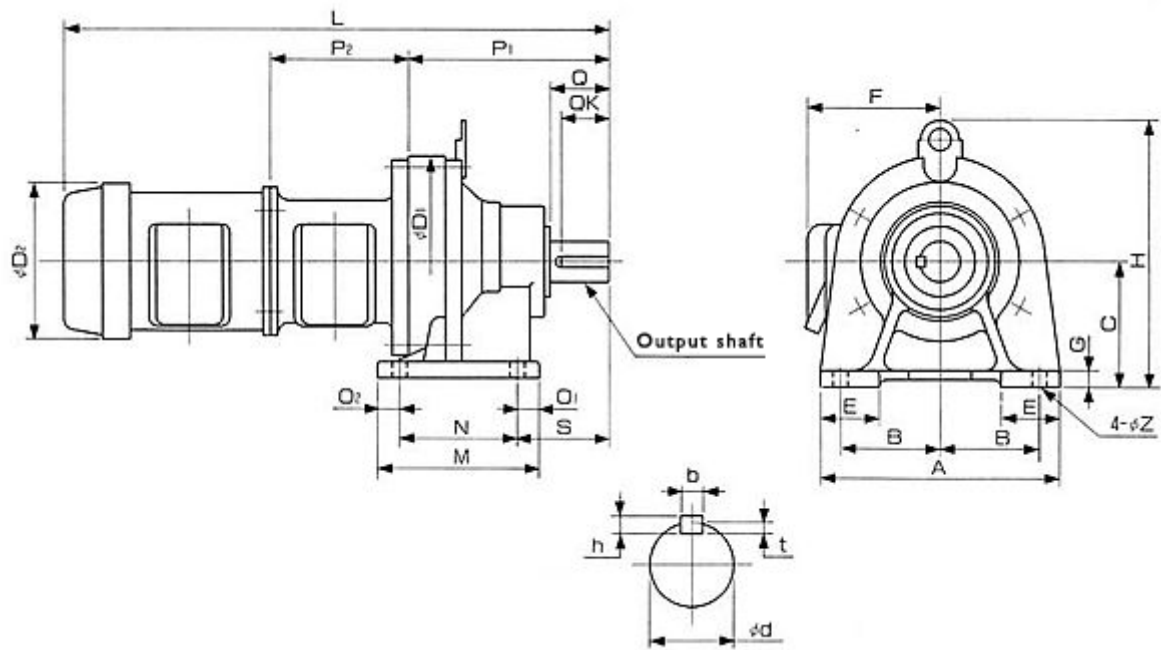

Unit:mm

Type		CHHCM3-6125-EP	Shaft direction		Shaft edge	
Diameter direction	A	230	L	674.5	Q	55
	B	95	M	155	QK	50
	C	120	N	115	d	38
	D ₁	204	O ₁	20	b	10
	D ₂	202	O ₂	20	h	8
	E	60	P ₁	186	t	5
	F	160	P ₂	178		
	G	15	S	82		
	H	275	Z	14		

Unit with cyclo speed reducer (Cyclo pack)

<CHHCM1-6135-EP>

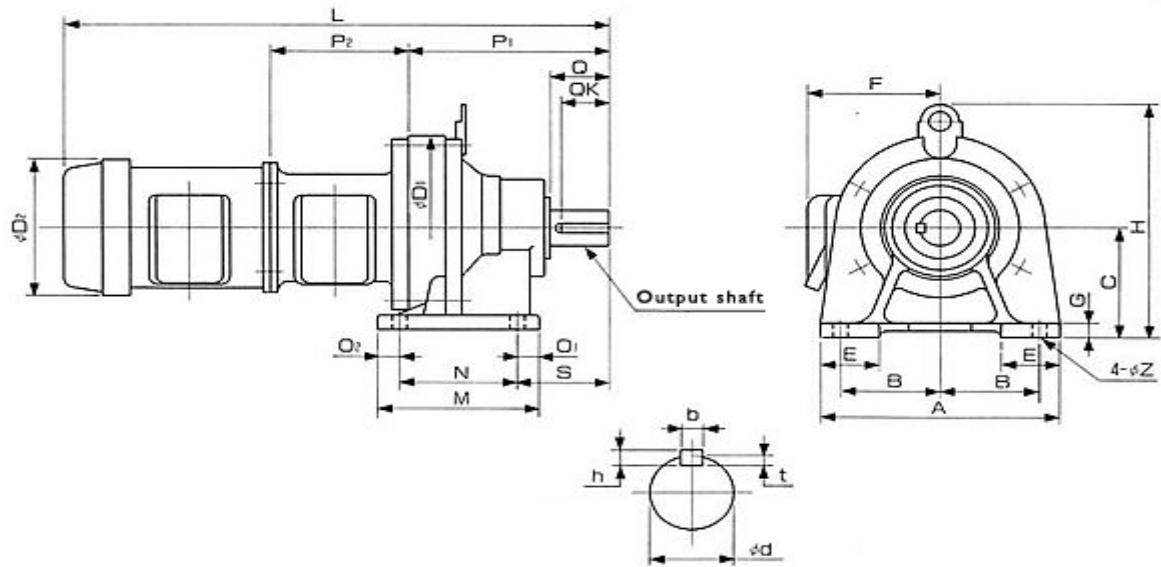

Unit:mm

Type		CHHCM1-6135-EP	Shaft direction		Shaft edge	
Diameter direction	A	2330	L	636	Q	70
	B	145	M	195	QK	56
	C	150	N	145	d	50
	D ₁	230	O	25	b	14
	D ₂	162	P ₁	240	h	9
	E	65	P ₂	141	t	5.5
	F	127	S	100		
	G	22	Z	18		
	H	264	QJ	M10×18		

Unit with cyclo speed reducer (Cyclo pack)

<CHHCM1-6145-EP>

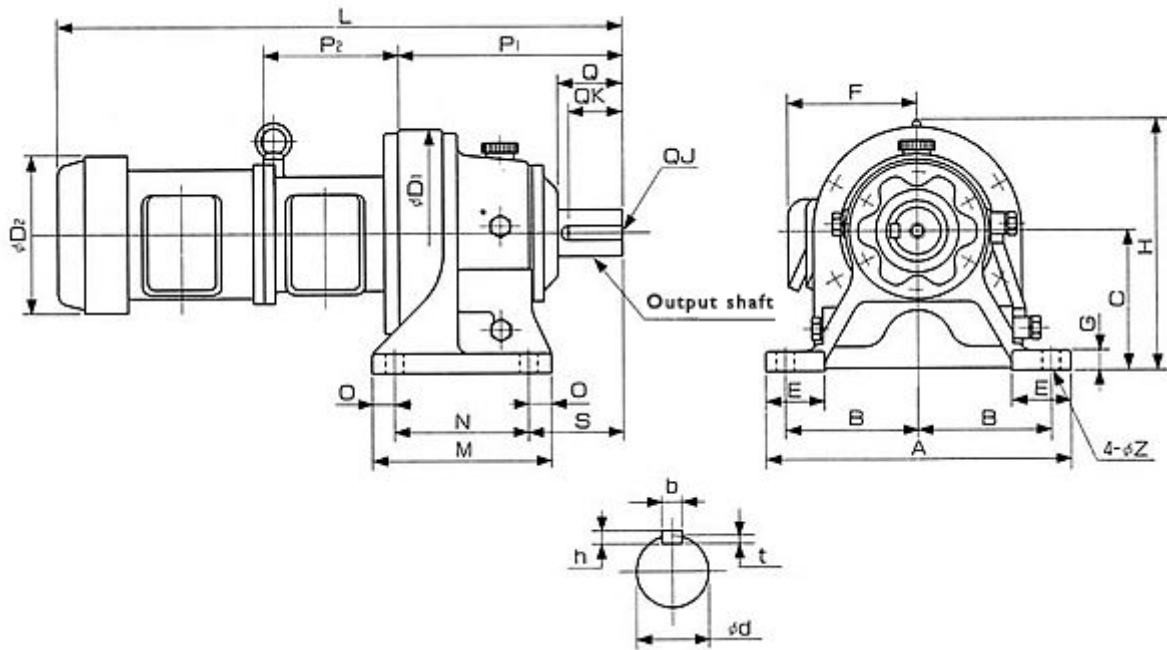

Unit:mm

Type		CHHCM1-6145-EP	Shaft direction		Shaft edge	
Diameter direction	A	330	L	656	Q	90
	B	145	M	195	QK	80
	C	150	N	145	d	50
	D ₁	230	O	25	b	14
	D ₂	162	P ₁	260	h	9
	E	65	P ₂	141	t	5.5
	F	127	S	120		
	G	22	Z	18		
	H	264	QJ	M10×18		

Unit with cyclo speed reducer (Cyclo pack)

<CHHCM2-6135-EP>

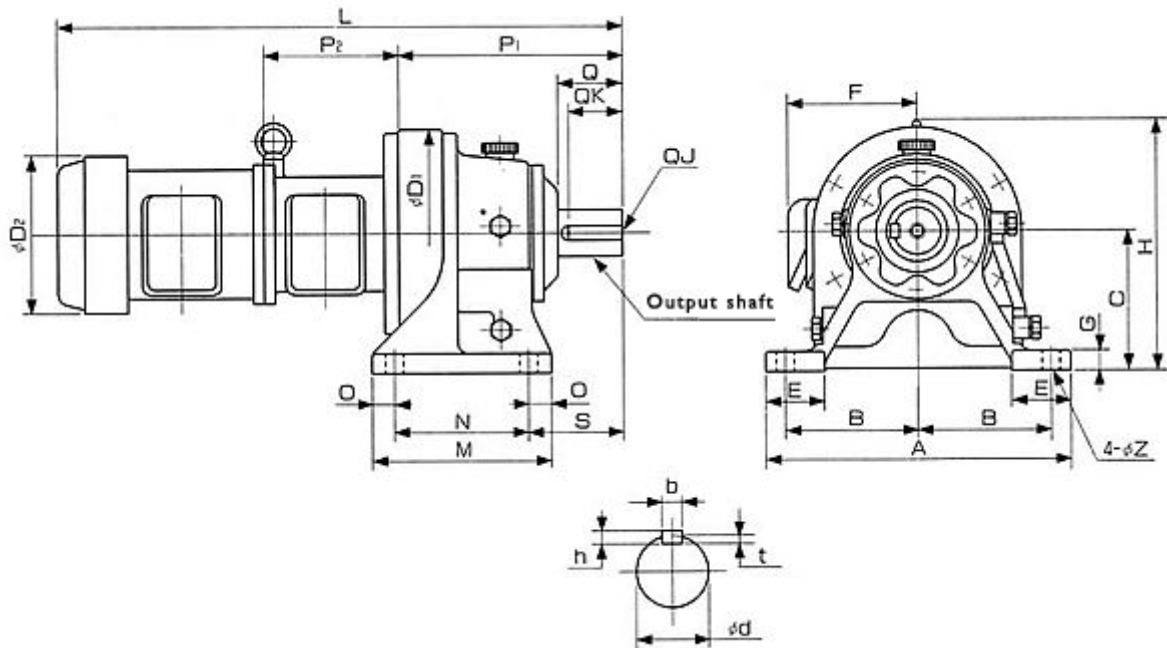

Unit:mm

Type		CHHCM2-6135-EP	Shaft direction		Shaft edge	
Diameter direction	A	330	L	663.5	Q	70
	B	145	M	195	QK	56
	C	150	N	145	d	50
	D ₁	230	O	25	b	14
	D ₂	202	P ₁	240	h	9
	E	65	P ₂	161	t	5.5
	F	148	S	100		
	G	22	Z	18		
	H	289	QJ	M10×18		

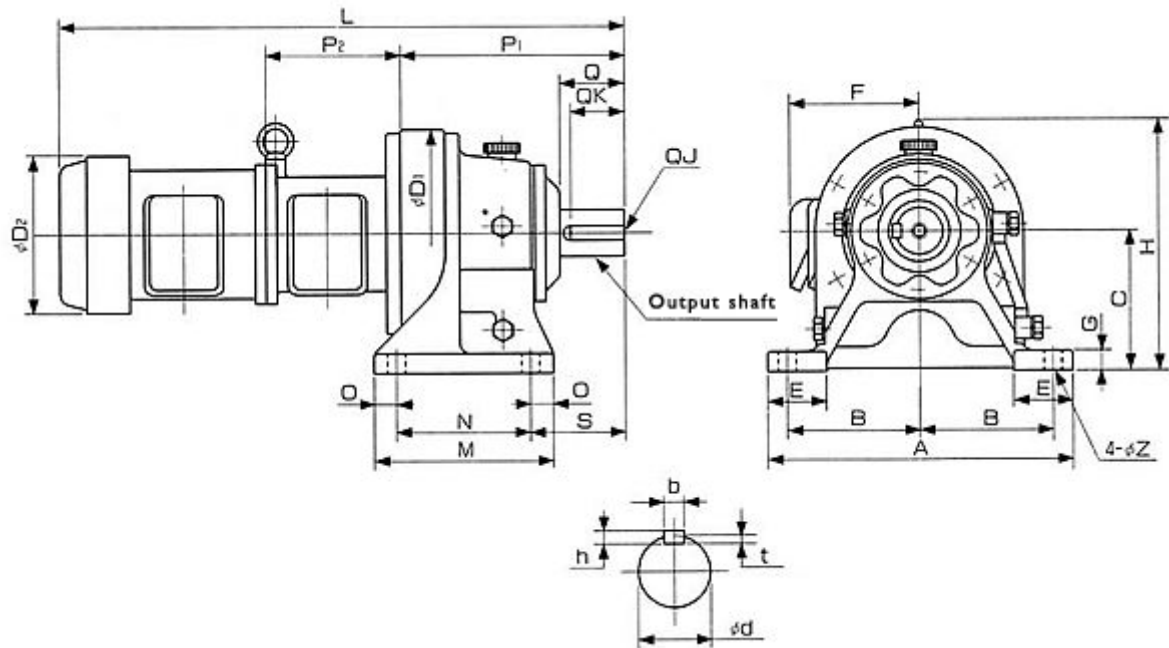
Unit with cyclo speed reducer (Cyclo pack)
<CHHCM2-6145-EP>

Unit:mm

Type		CHHCM2-6145-EP	Shaft direction		Shaft edge	
Diameter direction	A	330	L	683.5	Q	90
	B	145	M	195	QK	80
	C	150	N	145	d	50
	D ₁	230	O	25	b	14
	D ₂	202	P ₁	260	h	9
	E	65	P ₂	161	t	5.5
	F	148	S	120		
	G	22	Z	18		
	H	289	QJ	M10×18		

Unit with cyclo speed reducer (Cyclo pack)

<CHHCM3-6135-EP>

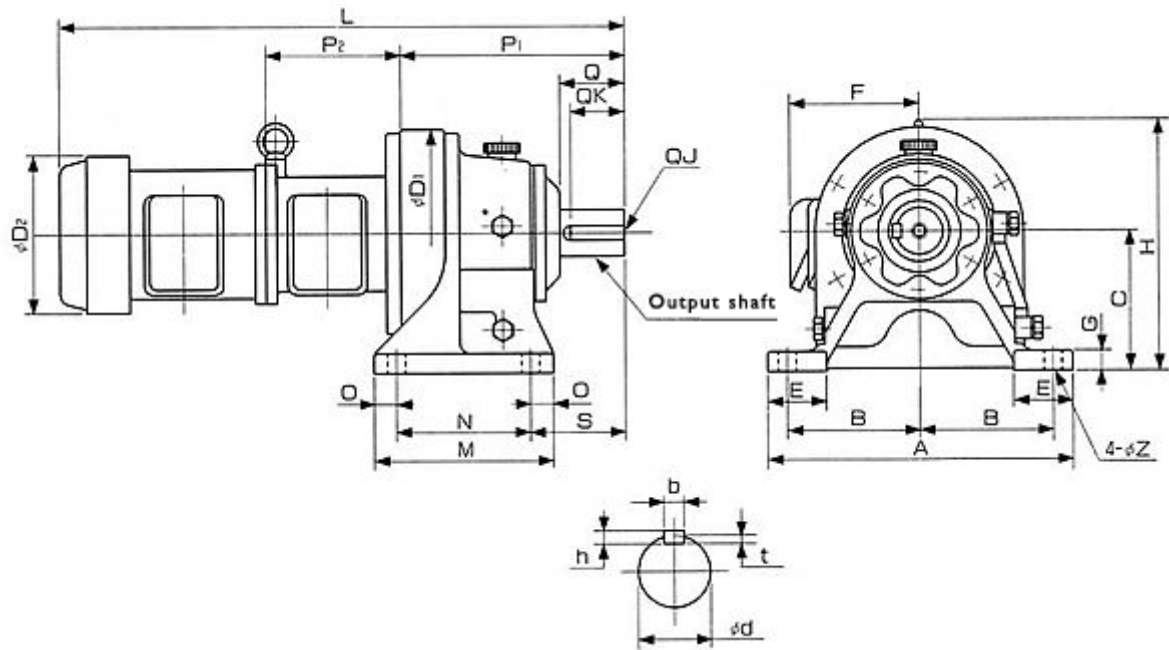

Unit:mm

Type		CHHCM3-6135-EP	Shaft direction		Shaft edge	
Diameter direction	A	330	L	728	Q	70
	B	145	M	195	QK	56
	C	150	N	145	d	50
	D ₁	230	O	25	b	14
	D ₂	202	P ₁	240	h	9
	E	65	P ₂	178	t	5.5
	F	160	S	100		
	G	22	Z	18		
	H	305	QJ	M10×18		

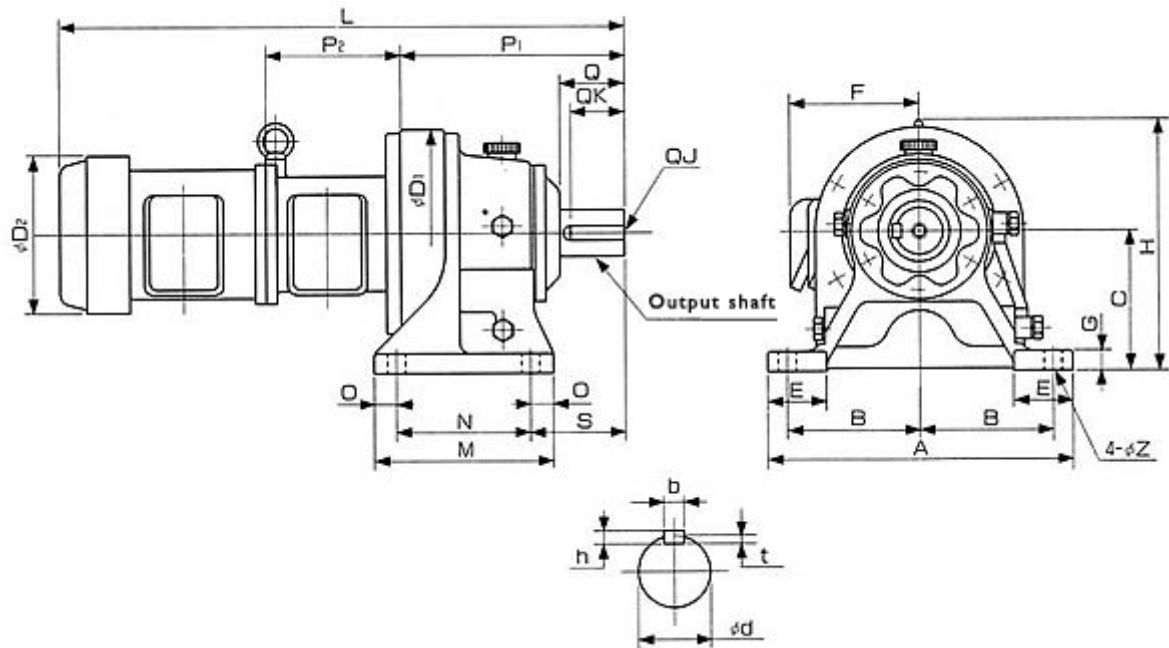
Unit with cyclo speed reducer (Cyclo pack)
<CHHCM3-6145-EP>

Unit:mm

Type		CHHCM3-6145-EP	Shaft direction		Shaft edge	
Diameter direction	A	330	L	748.5	Q	90
	B	145	M	195	QK	80
	C	150	N	145	d	50
	D ₁	230	O	25	b	14
	D ₂	202	P ₁	260	h	9
	E	65	P ₂	178	t	5.5
	F	160	S	120		
	G	22	Z	18		
	H	305	QJ	M10×18		

Unit with cyclo speed reducer (Cyclo pack)

<CHHCM5-6135-EP>

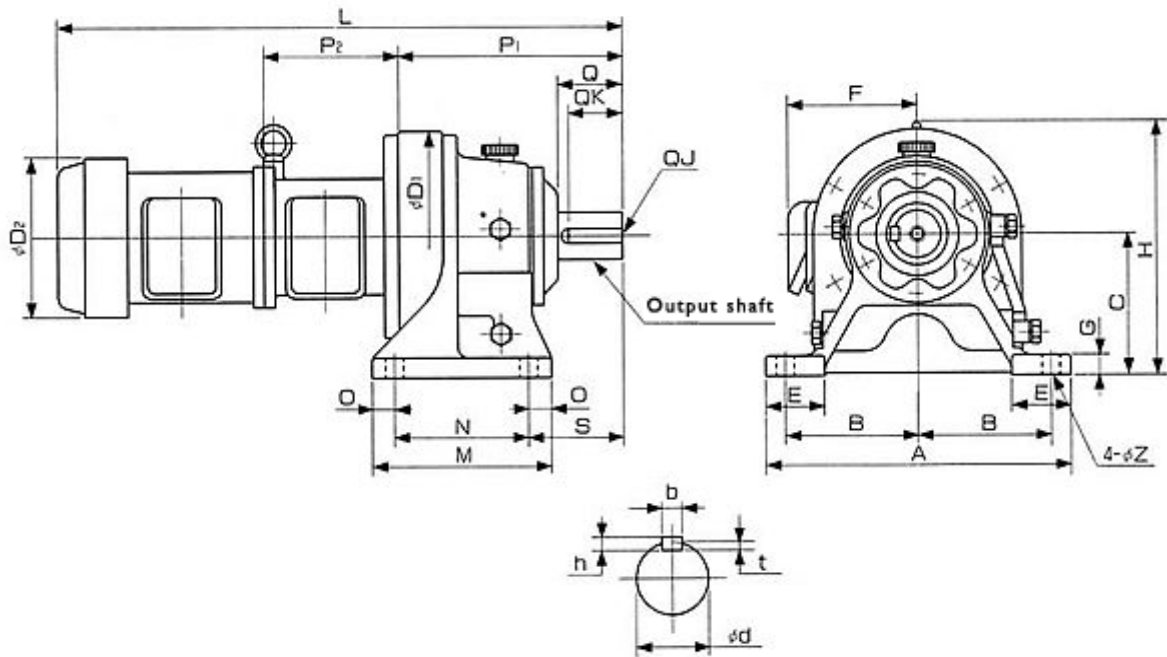

Unit:mm

Type		CHHCM5-6135-EP	Shaft direction		Shaft edge	
Diameter direction	A	330	L	820	Q	70
	B	145	M	195	QK	56
	C	150	N	145	d	50
	D ₁	230	O	25	b	14
	D ₂	235	P ₁	240	h	9
	E	65	P ₂	226	t	5.5
	F	179	S	100		
	G	22	Z	18		
	H	344	QJ	M10×18		

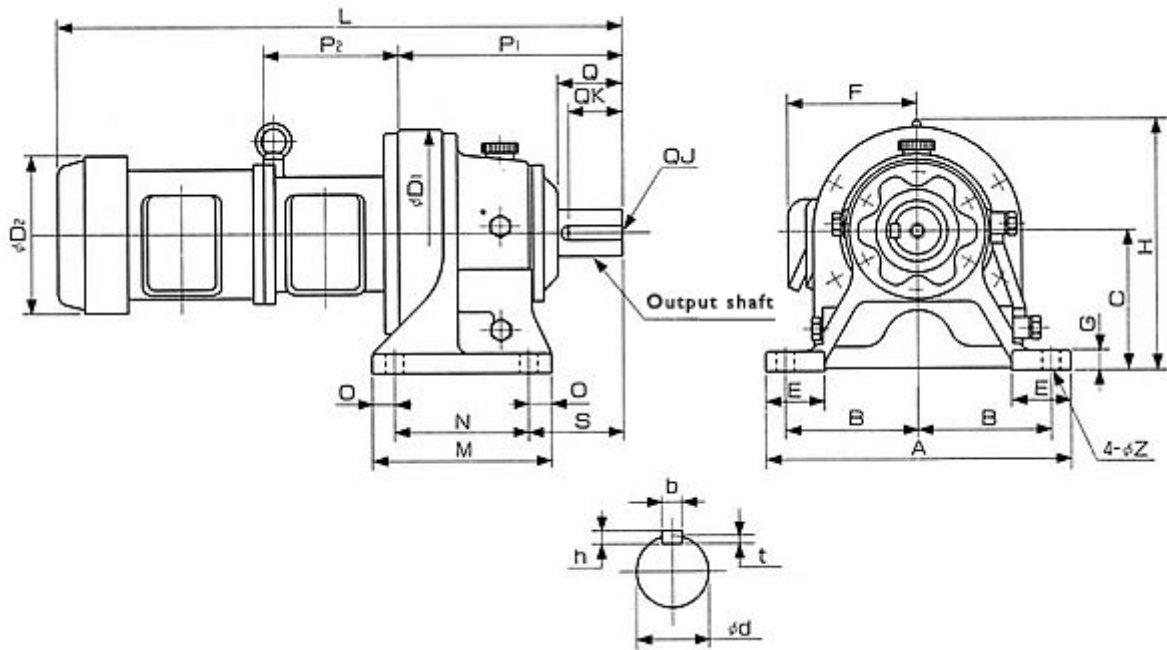
Unit with cyclo speed reducer (Cyclo pack)
<CHHCM5-6145-EP>

Unit:mm

Type		CHHCM5-6145-EP	Shaft direction		Shaft edge	
Diameter direction	A	330	L	840	Q	90
	B	145	M	195	QK	80
	C	150	N	145	d	50
	D ₁	230	O	25	b	14
	D ₂	235	P ₁	260	h	9
	E	65	P ₂	226	t	5.5
	F	179	S	120		
	G	22	Z	18		
	H	344	QJ	M10×18		

Unit with cyclo speed reducer (Cyclo pack)

<CHHCM5-6165-EP>

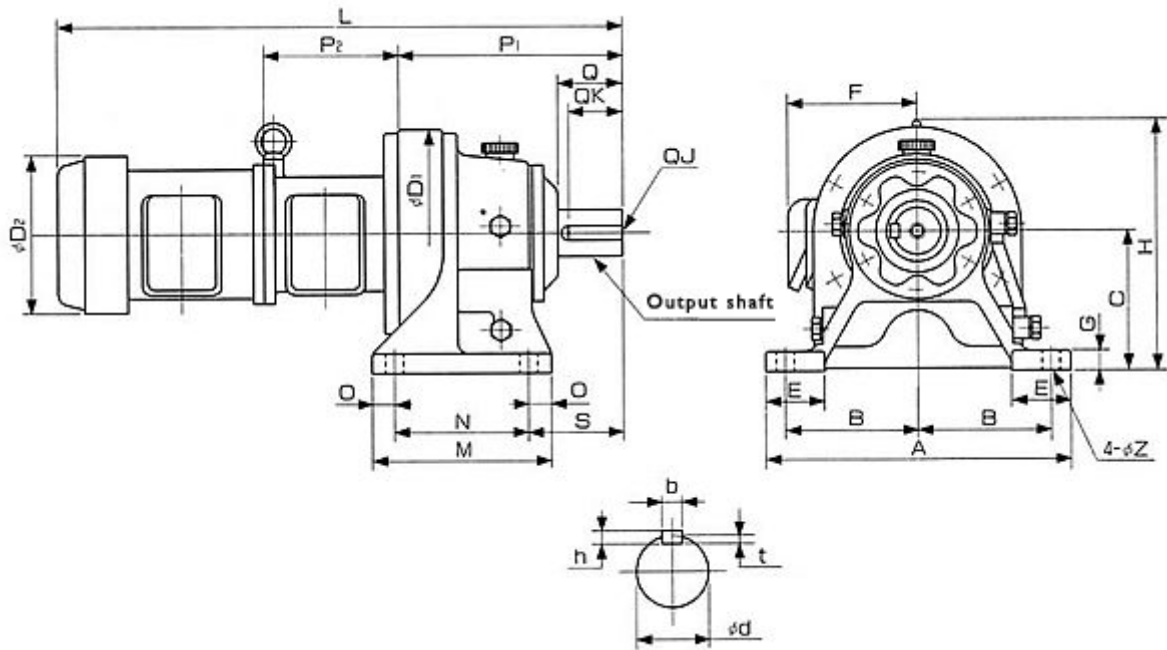

Unit:mm

Type		CHHCM5-6165-EP	Shaft direction		Shaft edge	
Diameter direction	A	410	L	870	Q	90
	B	185	M	238	QK	80
	C	160	N	150	d	60
	D ₁	300	O	44	b	18
	D ₂	235	P ₁	308	h	11
	E	75	P ₂	208	t	7
	F	179	S	139		
	G	25	Z	18		
	H	354	QJ	M10×18		

Unit with cyclo speed reducer (Cyclo pack)

<CHHCM8-6165-EP>

Productions on order.

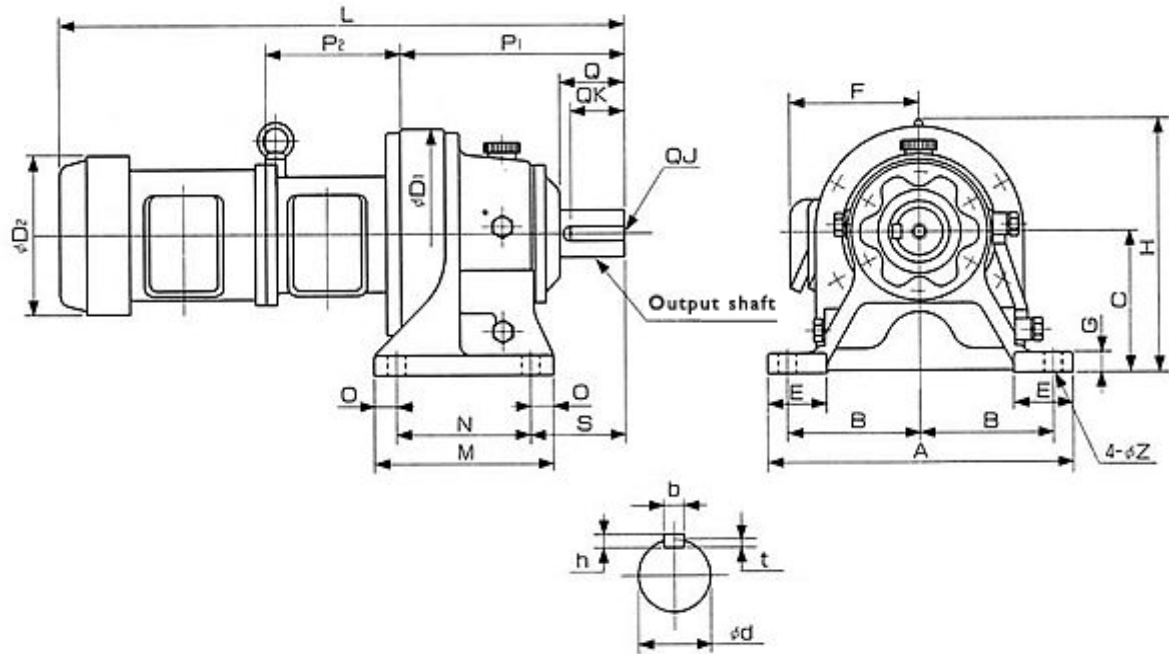

Unit:mm

Type		CHHCM8-6165-EP	Shaft direction		Shaft edge	
Diameter direction	A	410	L	888	Q	90
	B	185	M	238	QK	80
	C	160	N	150	d	60
	D ₁	300	O	44	b	18
	D ₂	272	P ₁	308	h	11
	E	75	P ₂	241	t	7
	F	200	S	139		
	G	25	Z	18		
	H	361	QJ	M10×18		

Unit with cyclo speed reducer (Cyclo pack)

<CHHCM8-6175-EP>

Productions on order.

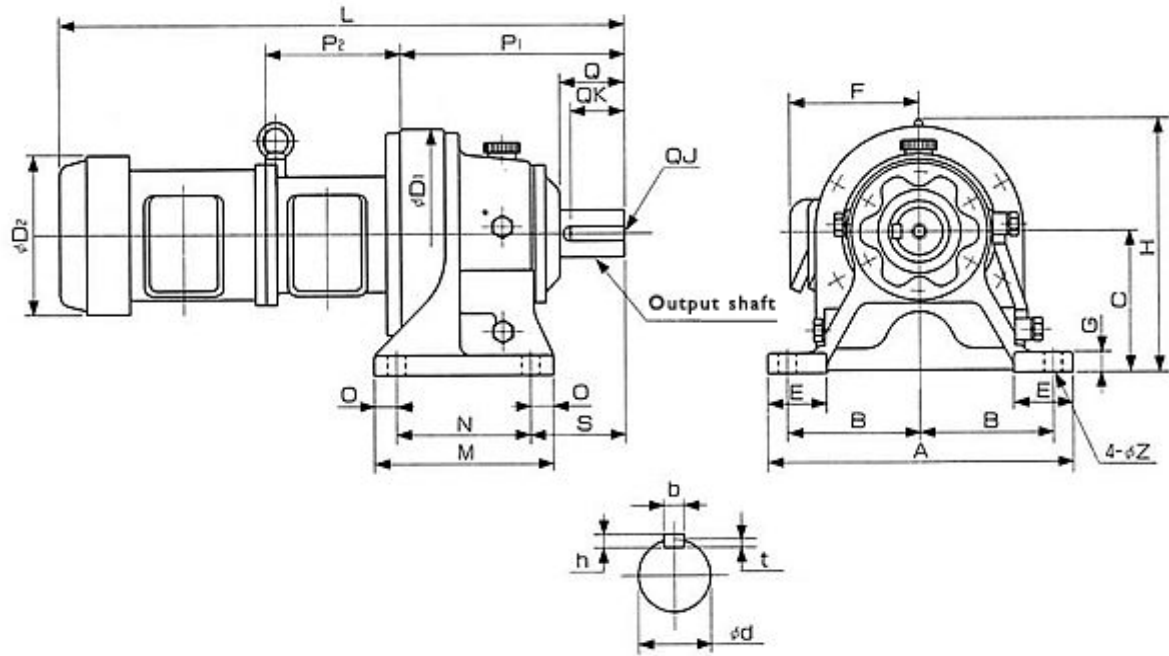

Unit:mm

Type		CHHCM8-6175-EP	Shaft direction		Shaft edge	
Diameter direction	A	430	L	947	Q	90
	B	190	M	335	QK	80
	C	200	N	275	d	70
	D ₁	340	O	30	b	20
	D ₂	272	P ₁	352	h	12
	E	80	P ₂	256	t	7.5
	F	200	S	125		
	G	30	Z	22		
	H	401	QJ	M12×24		

Unit with cyclo speed reducer (Cyclo pack)

<CHHCM10-6165-EP>

Productions on order.

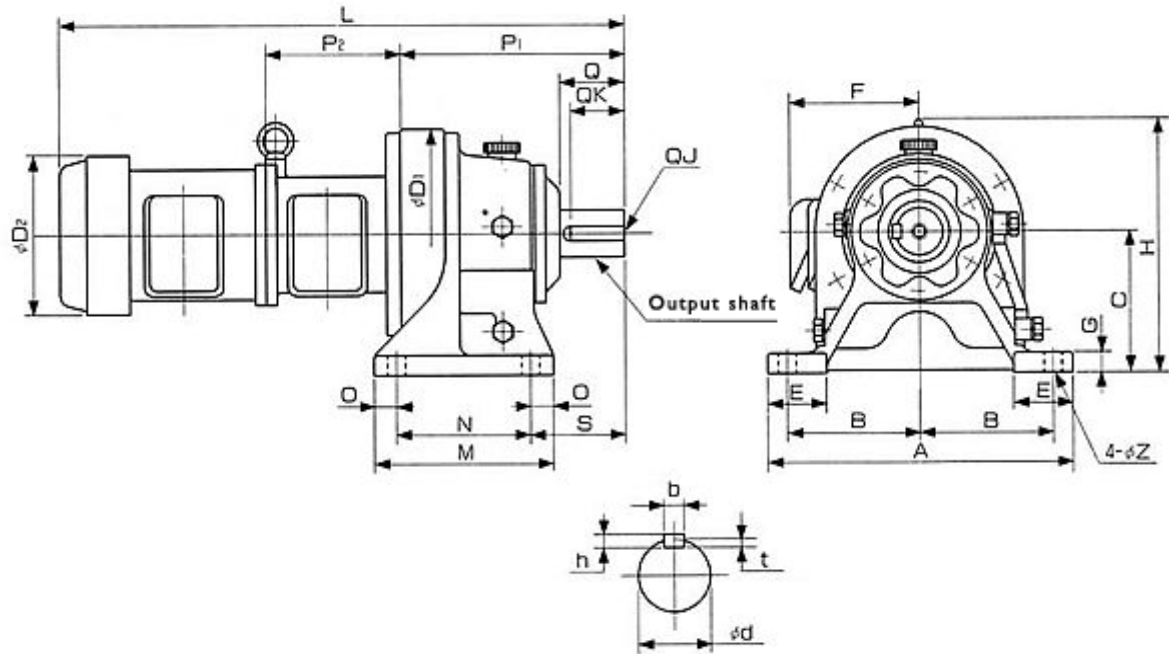

Unit:mm

Type		CHHCM10-6165-EP	Shaft direction		Shaft edge	
Diameter direction	A	410	L	926	Q	90
	B	185	M	238	QK	80
	C	160	N	150	d	60
	D ₁	300	O	44	b	18
	D ₂	272	P ₁	308	h	11
	E	75	P ₂	241	t	7
	F	200	S	139		
	G	25	Z	18		
	H	361	QJ	M10×18		

Unit with cyclo speed reducer (Cyclo pack)

<CHHCM10-6175-EP>

Productions on order.

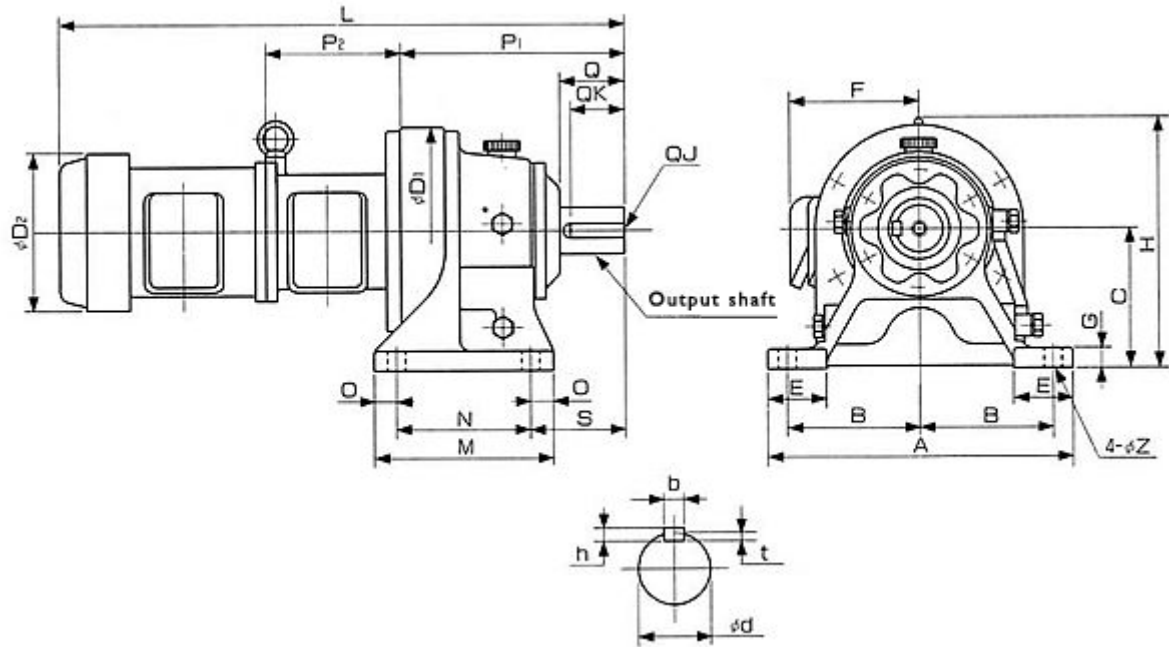

Unit:mm

Type		CHHCM10-6175-EP	Shaft direction		Shaft edge	
Diameter direction	A	430	L	985	Q	90
	B	190	M	335	QK	80
	C	200	N	275	d	70
	D ₁	340	O	30	b	20
	D ₂	272	P ₁	352	h	12
	E	80	P ₂	256	t	7.5
	F	200	S	125		
	G	30	Z	22		
	H	401	QJ	M12×24		

Unit with cyclo speed reducer (Cyclo pack)

<CHHCM10-6185-EP>

Productions on order.

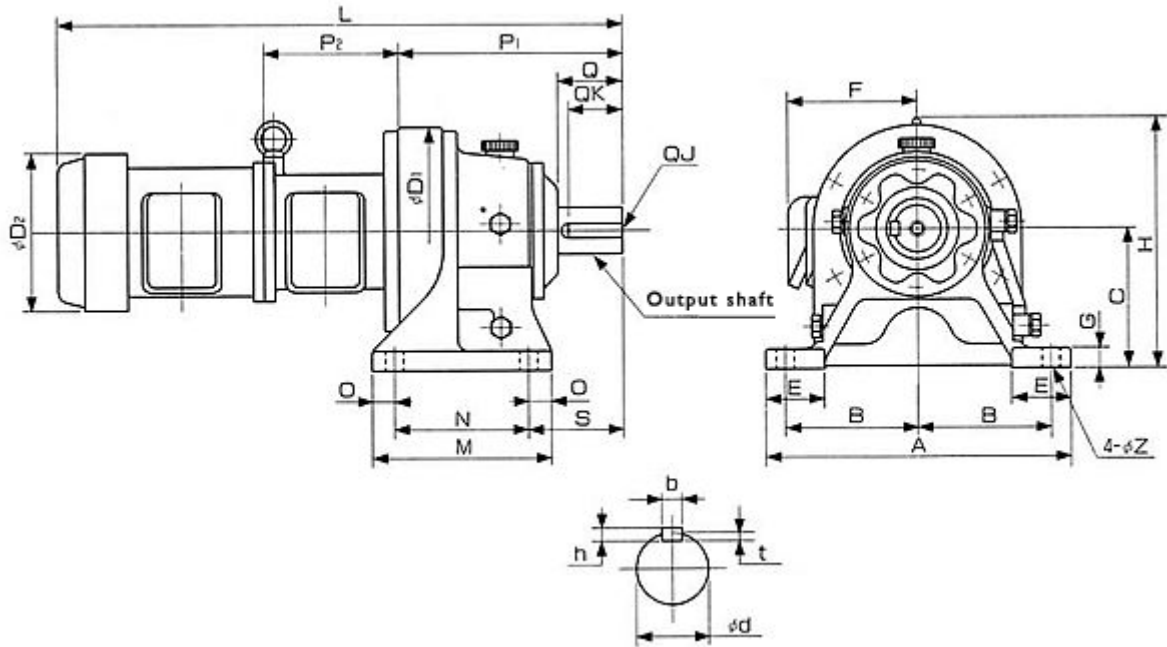

Unit:mm

Type		CHHCM10-6185-EP	Shaft direction		Shaft edge	
Diameter direction	A	470	L	1027	Q	110
	B	210	M	380	QK	100
	C	220	N	320	d	80
	D ₁	370	O	30	b	22
	D ₂	272	P ₁	389	h	14
	E	85	P ₂	261	t	9
	F	200	S	145		
	G	30	Z	22		
	H	421	QJ	M12×24		