

DRAWING NO.  
MFH33-A

NO.	DESCRIPTION	SPEC'	MAT'L	Q'TY	T/W	REMARK
-----	-------------	-------	-------	------	-----	--------

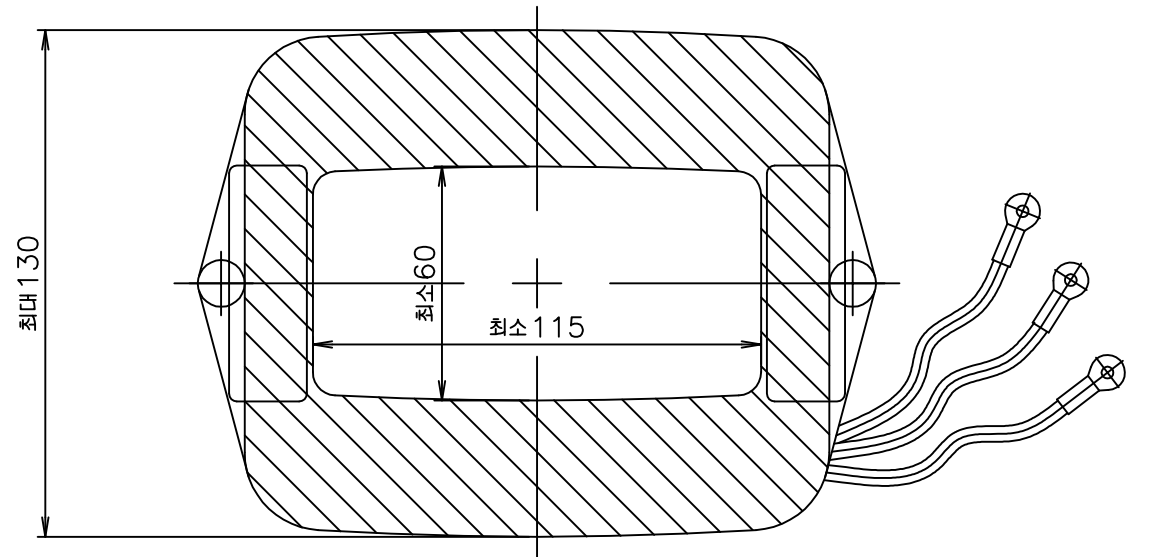

COIL SPECIFICATION		
MODEL	FH-33B	
CURRENT(A)	200V(220V)	14 A
	400V(440V)	7 A

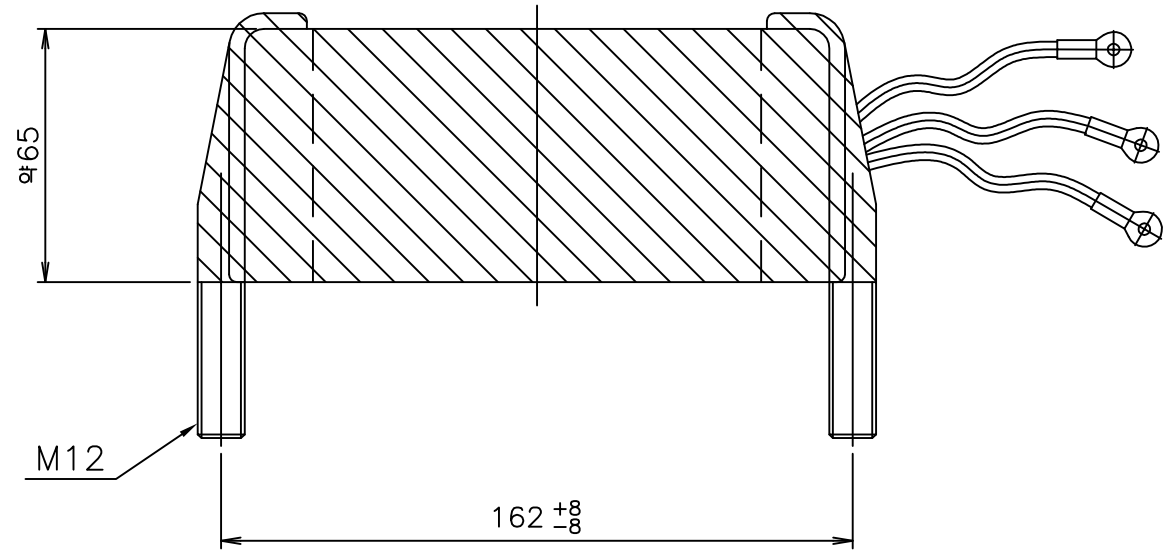

MARK	DESCRIPTION	NAME	DATE.

REVISIONS RECORD

NO.	DESCRIPTION	SPEC'	MAT'L	Q'TY	T/W	REMARK
CUSTOMER.		-				
NAME:		MAGNETIC FEEDER D/UNIT FH-33BDT COIL				
DRAWING NO.		MFH33-A				
APPROVED	CHECKED	DESIGNED	DRAWN	SCALE: 1/2	DATE: 2022.01.24	
	2022.01.24	LEE	2022.01.24	REV. 1	SH NO. 1	OF 1