

MFMS3012-A
DRAWING NO.

SPECIFICATION			
MATERIAL TO BE HANDLED	-	DRIVE UNIT	F-33BDT
BULK DENSITY	- T/m ³	VOLTAGE	- Vx - Hz
CAPACITY	- Ton/Hr	VIBRATION	3600VPM
GRAIN SIZE(mm)	-	CONTROLLER	-
MOISTURE(%)	-	Q'TY	-
TEMPERATURE(°C)	-	APP. WEIGHT	700kg

NO.	DESCRIPTION	SPEC'	MAT'L	Q'TY	T/W	REMARK
01	DRIVE UNIT	F-33BDT	PUR.	1		SINFONIA
02	TROUGH	-	SS275	1		
03	YOKE	-	SS275	2		
04	LINER	3t	STS304	1		
05	COVER	-	SS275	1		
06	HANGERASS'Y	-	SS275 SUP6	1		DRIVE
07	HANGERASS'Y	-	SS275 SUP6	1		TROUGH

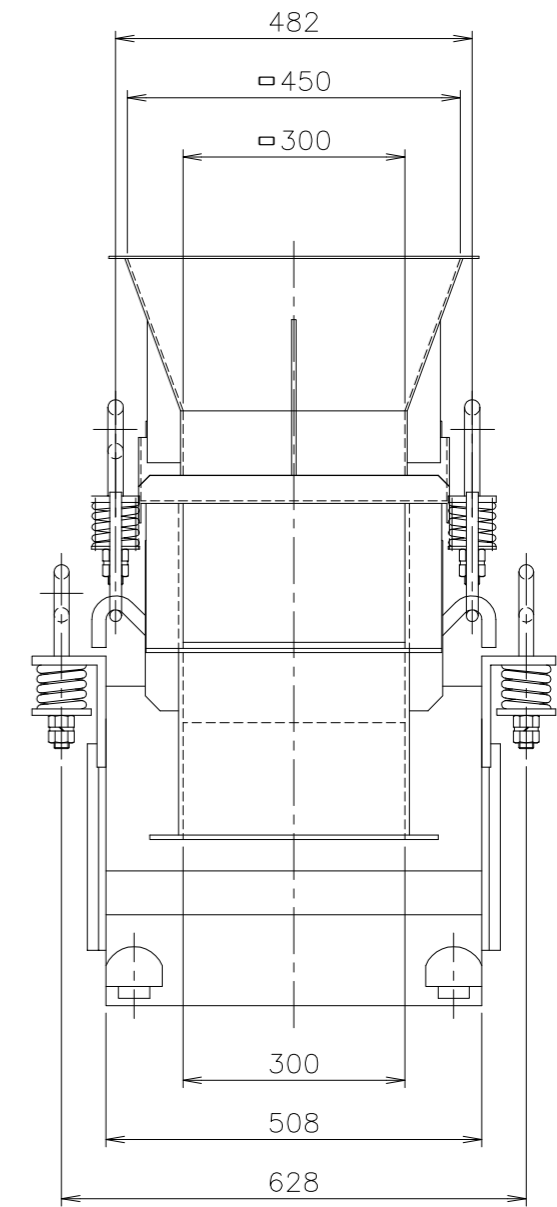
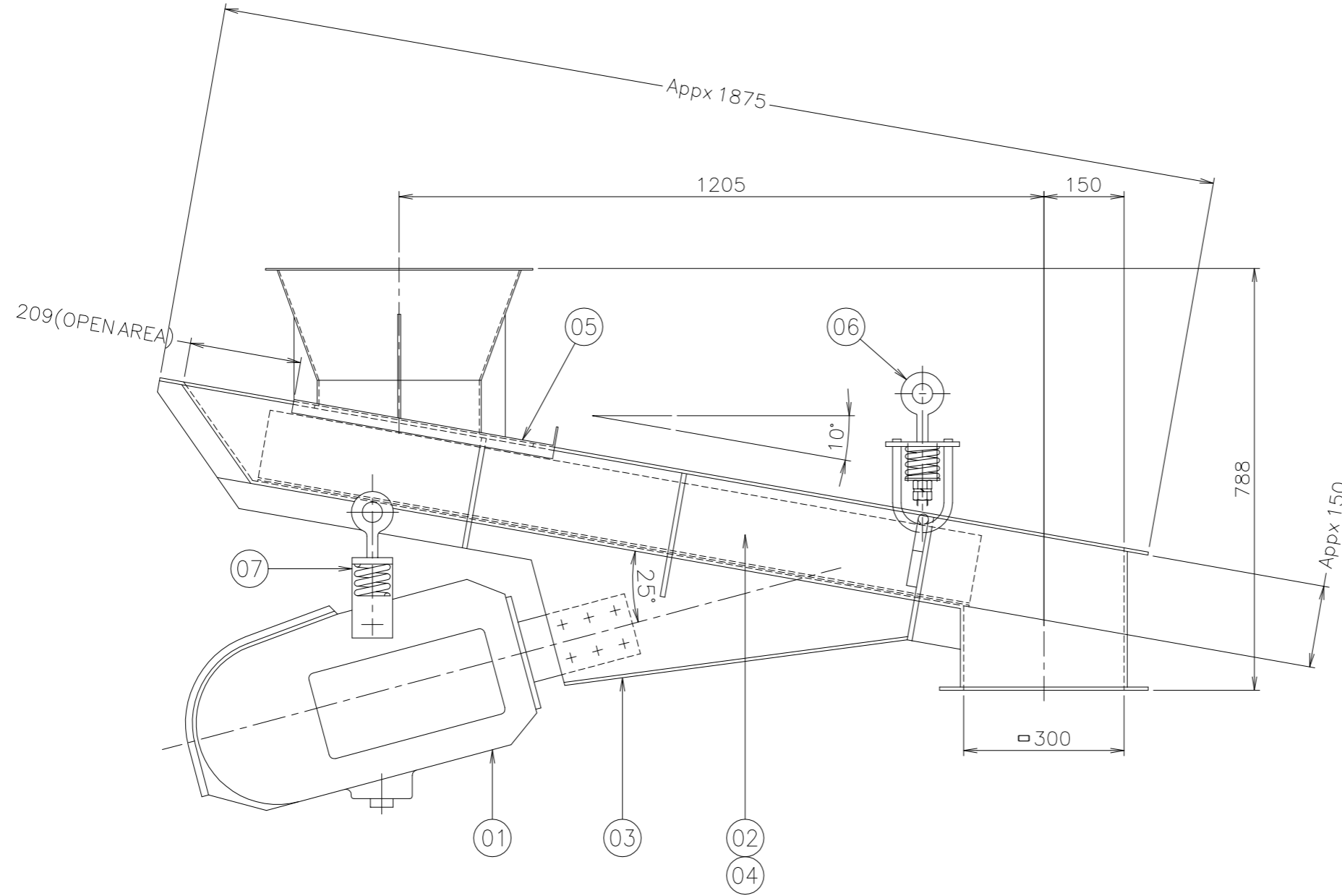

MARK	DESCRIPTION	NAME	DATE.
REVISIONS RECORD			

NO.	DESCRIPTION	SPEC'	MAT'L	Q'TY	T/W	REMARK
CUSTOMER. -			NAME: F-33BDT-C1103012			
			DRAWING NO. MFMS3012-A			
APPROVED		CHECKED	DESIGNED	DRAWN	SCALE: 1/5	DATE: 2022.12.12
		HONG	LEE		REV. 0	SH NO. 1 OF 1